



**PCM54**  
**PCM55**

DESIGNED FOR AUDIO

## 16-Bit Monolithic DIGITAL-TO-ANALOG CONVERTERS

### FEATURES

- PARALLEL INPUT FORMAT
- 16-BIT RESOLUTION
- 15-BIT MONOTONICITY (typ)
- -92dB TOTAL HARMONIC DISTORTION (K Grade)
- 3 $\mu$ s SETTling TIME (Voltage Out)
- 96dB DYNAMIC RANGE
- $\pm$ 3V or  $\pm$ 1mA AUDIO OUTPUT
- OPERATES ON  $\pm$ 5V (PCM55) TO  $\pm$ 12V (PCM54) SUPPLIES
- 28-PIN DIP (PCM54)
- 24-LEAD SOIC (PCM55)

### DESCRIPTION

The PCM54 and PCM55 family of converters are parallel input, fully monotonic, 16-bit digital-to-analog converters that are designed and specified for digital audio applications. These devices employ ultra-stable nichrome (NiCr) thin-film resistors to provide monotonicity, low distortion, and low differential linearity error (especially around bipolar zero) over long periods of time and over the full operating temperature.

These converters are completely self-contained with a stable, low noise, internal, zener voltage reference; high speed current switches; a resistor ladder network; and a fast settling, low noise output operational amplifier all on a single monolithic chip. The converters are operated using two power supplies that

can range from  $\pm$ 5V (PCM55) to  $\pm$ 12V (PCM54). Power dissipation with  $\pm$ 5V supplies is typically less than 200mW. Also included is a provision for external adjustment of the MSB error (differential linearity error at bipolar zero, PCM54 only) to further improve Total Harmonic Distortion (THD) specifications if desired.

A current output ( $I_{OUT}$ ) wiring option is provided. This output typically settles to within  $\pm$ 0.006% of FSR final value in 350ns (in response to a full-scale change in the digital input code).

The PCM54 is packaged in 28-pin plastic DIP package. The PCM55 is available in a 24-lead plastic mini-flatpak.

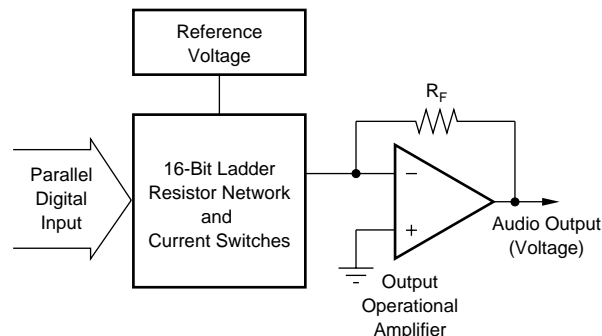

International Airport Industrial Park • Mailing Address: PO Box 11400, Tucson, AZ 85734 • Street Address: 6730 S. Tucson Blvd., Tucson, AZ 85706 • Tel: (520) 746-1111 • Twx: 910-952-1111  
Internet: <http://www.burr-brown.com/> • FAXLine: (800) 548-6133 (US/Canada Only) • Cable: BBRCORP • Telex: 066-6491 • FAX: (520) 889-1510 • Immediate Product Info: (800) 548-6132

# SPECIFICATIONS

## ELECTRICAL

At +25°C and  $\pm V_{CC} = 12V$ , unless otherwise noted.

PARAMETER	PCM54HP, PCM55HP			PCM54JP, PCM55JP			PCM54KP			UNITS
	MIN	TYP	MAX	MIN	TYP	MAX	MIN	TYP	MAX	
<b>DIGITAL INPUTS</b>										
Resolution		16			*			*		Bits
Dynamic Range		96			*			*		dB
Logic Levels (TTL/CMOS Compatible):										
$V_{IH}$	+2.4		+5.25	*		*	*		*	V
$V_{IL}$	0		+0.8	*		*	*		*	V
$I_{IH}, V_{IN} = +2.7V$			+40			*			*	$\mu A$
$I_{IL}, V_{IN} = +0.4V$			-0.5			*			*	mA
<b>TRANSFER CHARACTERISTICS</b>										
<b>ACCURACY</b>										
Gain Error		$\pm 2$			*			*		%
Bipolar Zero Error		$\pm 30$			*			*		mV
Differential Linearity Error at Bipolar Zero <sup>(1)</sup>		$\pm 0.001$			*			*		% FSR <sup>(2)</sup>
Noise (rms) (20Hz to 20kHz) at Bipolar Zero		12			*			*		$\mu V$
<b>TOTAL HARMONIC DISTORTION<sup>(3)</sup></b> (16-Bit Resolution)										
$V_O = \pm FS$ at $f = 991Hz$		-94	-82		*	-88	*	*	-92	dB
$V_O = -20dB$ at $f = 991Hz$		-74	-68		*	*	*	-80	-74	dB
$V_O = -60dB$ at $f = 991Hz$		-34	-28		*	*	*	-40	-34	dB
<b>MONOTONICITY</b>		15			*			*		Bits
<b>SETTLING TIME</b> (to $\pm 0.006\%$ of FSR)										
Voltage Output: 6V Step		3			*			*		$\mu s$
1LSB Step		1			*			*		$\mu s$
Current Output (1mA Step): 10 $\Omega$ to 100 $\Omega$ Load		350			*			*		ns
1k $\Omega$ Load <sup>(4)</sup>		350			*			*		ns
Deglitcher Delay (THD Test) <sup>(5)</sup>		2.5	4		*	*		*	*	$\mu s$
Slew Rate		10			*			*		V/ $\mu s$
<b>WARM-UP TIME</b>	1			*			*			Min
<b>ANALOG OUTPUT</b>										
Voltage Output: Bipolar Range		$\pm 3$			*			*		V
Output Current	$\pm 2$			*			*			mA
Output Impedance		0.1			*			*		$\Omega$
Short-Circuit Duration		Indefinite to Common			*			*		
Current Output: <sup>(6)</sup>										
Bipolar Range ( $\pm 30\%$ )		$\pm 1$			*			*		mA
Bipolar Output Impedance ( $\pm 30\%$ )		1.2			*			*		k $\Omega$
<b>POWER SUPPLY REQUIREMENTS</b>										
Voltage: $+V_{CC}$ (PCM54)	+4.75	+12	+15.75	*	*	*	*	*	*	V
$-V_{CC}$ (PCM54)	-4.75	-12	-15.75	*	*	*	*	*	*	V
$+V_{CC}$ (PCM55)	+4.75	+5	+7.5	*	*	*	*	*	*	V
$-V_{CC}$ (PCM55)	-4.75	-5	-7.5	*	*	*	*	*	*	V
Supply Drain: $+V_{CC}$		+13	+20		*	*		*	*	mA
$-V_{CC}$		-16	-25		*	*		*	*	mA
<b>TEMPERATURE RANGE</b>										
Operating	0		+70	*		*	*		*	$^{\circ}C$
Storage	-55		+100	*		*	*		*	$^{\circ}C$

\* Specifications same as for PCM54HP.

NOTES: (1) Externally adjustable. If external adjustment is not used, connect a 0.01 $\mu F$  capacitor to Common to reduce noise pickup. (2) FSR means Full-Scale Range and is 6V for  $\pm 3V$  output. (3) The measurement of total harmonic distortion is highly dependent on the characteristics of the measurement circuit. Burr-Brown may calculate THD from the measured linearity errors using Equation 2 in the section on "Total Harmonic Distortion," but specifies that the maximum THD measured with the circuit shown in Figure 2 will be less than the limits indicated. (4) Measured with an active clamp to provide a low impedance for approximately 200ns. (5) Deglitcher or sample/hold delay used in THD measurement test circuit. See Figures 2 and 3. (6) Output amplifier disconnected.

The information provided herein is believed to be reliable; however, BURR-BROWN assumes no responsibility for inaccuracies or omissions. BURR-BROWN assumes no responsibility for the use of this information, and all use of such information shall be entirely at the user's own risk. Prices and specifications are subject to change without notice. No patent rights or licenses to any of the circuits described herein are implied or granted to any third party. BURR-BROWN does not authorize or warrant any BURR-BROWN product for use in life support devices and/or systems.

## CONNECTION DIAGRAMS

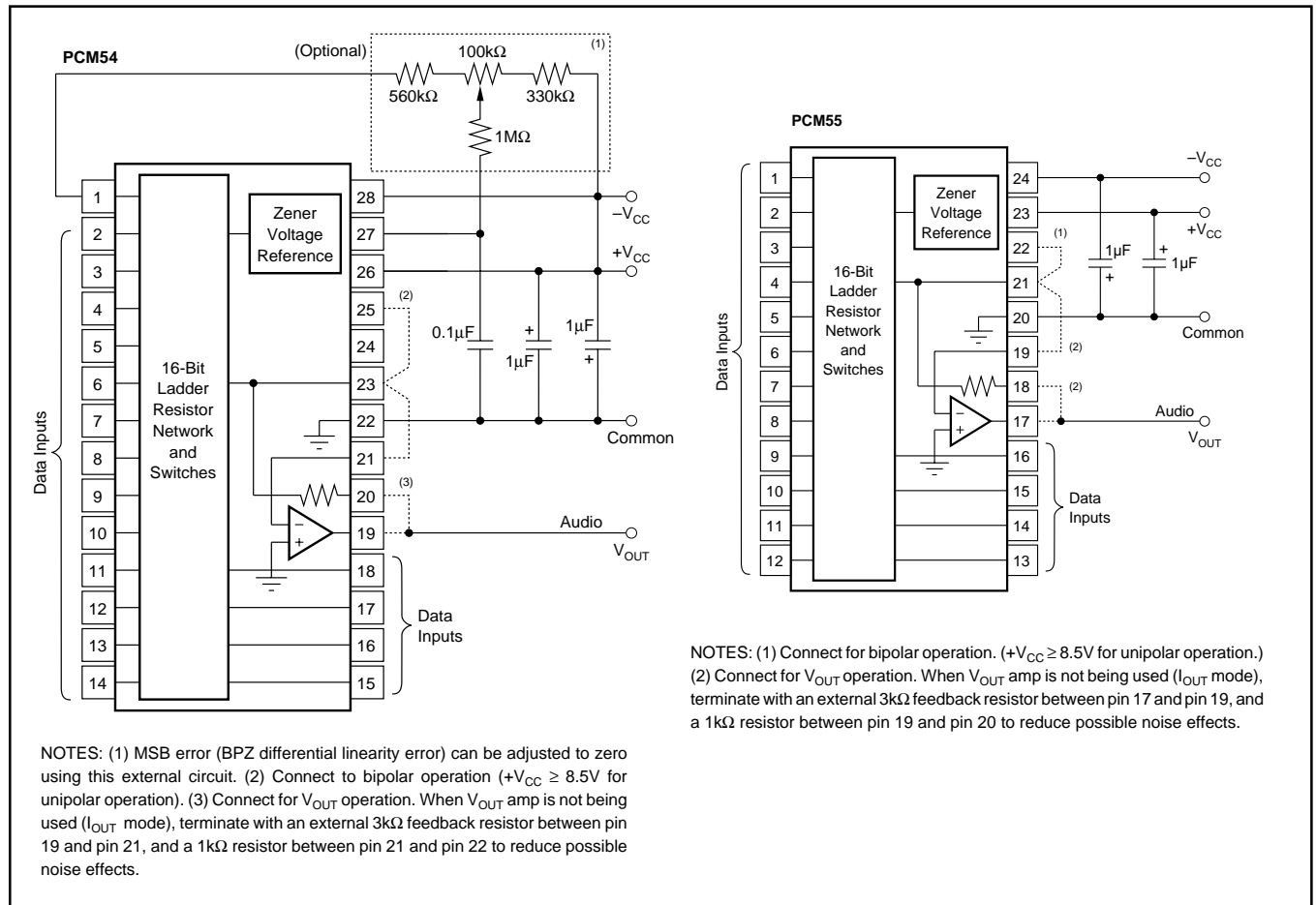

## PIN ASSIGNMENTS

PIN	PCM54-DIP	PIN	PCM54-DIP
1	Trim	15	Bit 13
2	Bit 1 (MSB)	16	Bit 14
3	Bit 2	17	Bit 15
4	NC	18	Bit 16 (LSB)
5	Bit 3	19	V <sub>OUT</sub>
6	Bit 4	20	R <sub>FB</sub>
7	Bit 5	21	SJ
8	Bit 6	22	Common
9	Bit 7	23	I <sub>OUT</sub>
10	Bit 8	24	NC
11	Bit 9	25	I <sub>BPO</sub>
12	Bit 10	26	+V <sub>CC</sub>
13	Bit 11	27	MSB Adjust
14	Bit 12	28	-V <sub>CC</sub>

## PACKAGE INFORMATION

PRODUCT	PACKAGE	PACKAGE DRAWING NUMBER <sup>(1)</sup>
PCM54HP	28-Pin DIP	215
PCM54JP	28-Pin DIP	215
PCM54KP	28-Pin DIP	215
PCM55HP	24-Lead SOIC	178
PCM55JP	24-Lead SOIC	178

NOTE: (1) For detailed drawing and dimension table, please see end of data sheet, or Appendix C of Burr-Brown IC Data Book.

## PIN ASSIGNMENTS

PIN	PCM55-SOIC	PIN	PCM55-SOIC
1	Bit 1 (MSB)	13	Bit 13
2	Bit 2	14	Bit 14
3	Bit 3	15	Bit 15
4	Bit 4	16	Bit 16
5	Bit 5	17	V <sub>OUT</sub>
6	Bit 6	18	Feedback Resistor
7	Bit 7	19	Summing Junction
8	Bit 8	20	Common
9	Bit 9	21	Current Output
10	Bit 10	22	Bipolar Offset
11	Bit 11	23	+V <sub>CC</sub>
12	Bit 12	24	-V <sub>CC</sub>

## ABSOLUTE MAXIMUM RATINGS

DC Supply Voltage	±18VDC
Input Logic Voltage	-1V to +5.5V
Power Dissipation	PCM54 800mW, PCM55 400mW
Storage Temperature	-55°C to +100°C
Lead Temperature, (soldering, 10s)	+300°C

## ORDERING INFORMATION

PRODUCT	THD at FS	PACKAGE
PCM54HP	0.008	28-Pin DIP
PCM54JP	0.004	28-Pin DIP
PCM54KP	0.0025	28-Pin DIP
PCM55HP	0.008	24-Lead SOIC
PCM55JP	0.004	24-Lead SOIC

# DISCUSSION OF SPECIFICATIONS

The PCM54 and PCM55 are specified to provide critical performance criteria for a wide variety of applications. The most critical specifications for a D/A converter in audio applications are total harmonic distortion, differential linearity error, bipolar zero error, parameter shifts with time and temperature, and settling time effects on accuracy.

The PCM54 and PCM55 are factory-trimmed and tested for all critical key specifications.

The accuracy of a D/A converter is described by the transfer function shown in Figure 1. Digital input to analog output relationship is shown in Table I. The errors in the D/A converter are combinations of analog errors due to the linear circuitry, matching and tracking properties of the ladder and scaling networks, power supply rejection, and reference errors. In summary, these errors consist of initial errors including gain, offset, linearity, differential linearity, and power supply sensitivity. Gain drift over temperature rotates

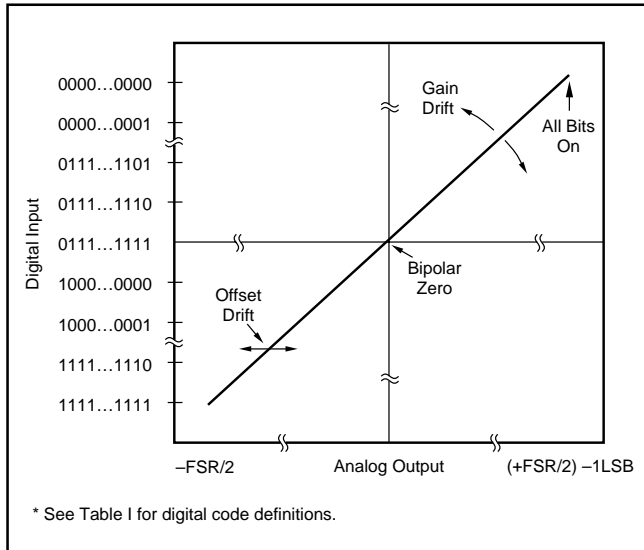

FIGURE 1. Input vs Output for an Ideal Bipolar D/A Converter.

the line (Figure 1) about the bipolar zero point and offset drift shifts the line left or right over the operating temperature range. Most of the offset and gain drift with temperature or time is due to the drift of the internal reference zener diode. The converter is designed so that these drifts are in opposite directions. This way, the bipolar zero voltage is virtually unaffected by variations in the reference voltage.

## DIGITAL INPUT CODES

The PCM54 and PCM55 accept complementary digital input codes in any of three binary formats (CSB, unipolar; or COB, bipolar; or CTC, Complementary Two's Complement, bipolar). See Table II.

Digital Input Codes	ANALOG OUTPUT		
	Complementary Straight Binary (CSB)	Complementary Offset Binary (COB)	Complementary Two's Complement (CTS) <sup>(1)</sup>
0000 <sub>H</sub>	+Full Scale	+Full Scale	-1LSB
7FFF <sub>H</sub>	+1/2 Full Scale	Bipolar Zero	-Full Scale
8000 <sub>H</sub>	+1/2 Full Scale	-1LSB	+Full Scale
FFFF <sub>H</sub>	-1LSB Zero	-Full Scale	Bipolar Zero

NOTE: (1) Invert the MSB of the COB code with an external inverter to obtain CTC code.

TABLE II. Digital Input Codes.

## BIPOLAR ZERO ERROR

Initial Bipolar Zero (BPZ) error (Bit 1 "ON" and all other bits "OFF") is the deviation from 0V out and is factory-trimmed to typically  $\pm 10\text{mV}$  at  $+25^\circ\text{C}$ .

## DIFFERENTIAL LINEARITY ERROR

Differential Linearity Error (DLE) is the deviation from an ideal 1LSB change from one adjacent output state to the next. DLE is important in audio applications because excessive DLE at bipolar zero (at the "major carry") can result in audible crossover distortion for low level output signals. Initial DLE on the PCM54 and PCM55 is factory-trimmed to typically  $\pm 0.001\%$  of FSR. This error is adjustable to zero using the circuit shown in the connection diagram (PCM54 only).

VOLTAGE OUTPUT MODE							
Digital Input Code		Analog Output					
		Unipolar <sup>(1)</sup>			Bipolar		
		16-Bit	15-Bit	14-Bit	16-Bit	15-Bit	14-Bit
One LSB	( $\mu\text{V}$ )	91.6	183	366	91.6	183	366
0000 <sub>H</sub>	(V)	+5.99991	+5.99982	+5.99963	+2.99991	+2.99982	+2.99963
FFFF <sub>H</sub>	(V)	0	0	0	-3.0000	-3.0000	-3.0000
CURRENT OUTPUT MODE							
Digital Input Code		Analog Output					
		Unipolar			Bipolar		
		16-Bit	15-Bit	14-Bit	16-Bit	15-Bit	14-Bit
One LSB	( $\mu\text{A}$ )	0.031	0.061	0.122	0.031	0.061	0.122
0000 <sub>H</sub>	(mA)	-1.99997	-1.99994	-1.99988	-0.99997	-0.99994	-0.99988
FFFF <sub>H</sub>	(mA)	0	0	0	+1.00000	+1.00000	+1.00000

NOTE: (1)  $+V_{CC}$  must be at least +8.5VDC to allow output to swing to +6.0VDC.

TABLE I. Digital Input to Analog Output Relationship.

## POWER SUPPLY SENSITIVITY

Changes in the DC power supplies will affect accuracy.

The PCM54 and PCM55 power supply sensitivity is shown by Figure 2. Normally, regulated power supplies with 1% or less ripple are recommended for use with the DAC. See also Power Supply Connections paragraph in the Installation and Operating Instructions section.

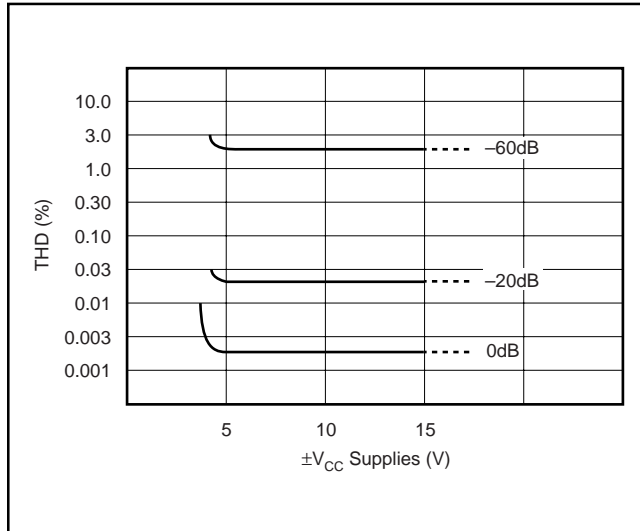

FIGURE 2. Effects of  $\pm V_{CC}$  on Total Harmonic Distortion (PCM54JP;  $V_{CC}$ s with approximately 2% ripple).

## SETTLING TIME

Settling time is the total time (including slew time) required for the output to settle within an error band around its final value after a change in input (see Figure 3).

Settling times are specified to  $\pm 0.006\%$  of FSR; one for a large output voltage change of 3V and one for a 1LSB change. The 1LSB change is measured at the major carry (0111...11 to 10000.00), the point at which the worst-case settling time occurs.

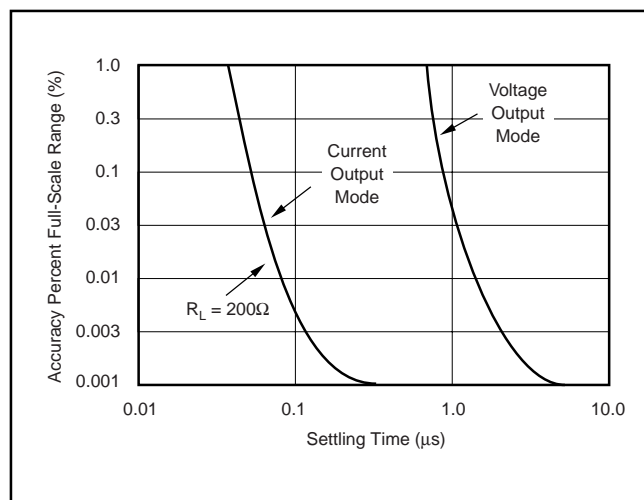

FIGURE 3. Full-Scale Range Settling Time vs Accuracy.

## STABILITY WITH TIME AND TEMPERATURE

The parameters of a D/A converter designed for audio applications should be stable over a relatively wide temperature range and over long periods of time to avoid undesirable periodic readjustment. The most important parameters are bipolar zero, differential linearity error, and total harmonic distortion. Most of the offset and gain drift with temperature or time is due to the drift of the internal reference zener diode. The PCM54 and PCM55 are designed so that these drifts are in opposite directions so that the bipolar zero voltage is virtually unaffected by variations in the reference voltage. Both DLE and THD are dependent upon the matching and tracking of resistor ratios and upon  $V_{BE}$  and  $h_{FE}$  of the current-source transistors. The PCM54 and PCM55 were designed so that any absolute shift in these components has virtually no effect on DLE or THD. The resistors are made of identical links of ultra-stable nichrome thin-film. The current density in these resistors is very low to further enhance their stability.

## DYNAMIC RANGE

The dynamic range is a measure of the ratio of the smallest signals the converter can produce to the full-scale range and is usually expressed in decibels (dB). The theoretical dynamic range of a converter is approximately  $6 \times n$ , or about 96dB for a 16-bit converter. The actual, or useful, dynamic range is limited by noise and linearity errors and is therefore somewhat less than the theoretical limit. However, this does point out that a resolution of at least 16 bits is required to obtain a 90dB minimum dynamic range, regardless of the accuracy of the converter. Another specification that is useful for audio applications is total harmonic distortion.

## TOTAL HARMONIC DISTORTION

THD is useful in audio applications and is a measure of the magnitude and distribution of the linearity error, differential linearity error, and noise as well as quantization error. To be useful, THD should be specified for both high level and low level input signals. This error is unadjustable and is the most meaningful indicator of D/A converter accuracy for audio applications.

The THD is defined as the ratio of the square root of the sum of the squares of the values of the harmonics to the value of the fundamental input frequency and is expressed in percent or dB. The rms value of the PCM54/55 error referred to the input can be shown to be:

(1)

$$\epsilon_{\text{rms}} = \sqrt{\frac{1}{n} \sum_{i=1}^n [E_L(i) + E_Q(i)]^2}$$

where  $n$  is the number of samples in one cycle of any given sine wave,  $E_L(i)$  is the linearity error of the PCM54 or PCM55 at each sampling point, and  $E_Q(i)$  is the quantization

error at each sampling point. The THD can then be expressed as:

(2)

$$\text{THD} = \frac{\epsilon_{\text{rms}}}{E_{\text{rms}}} = \sqrt{\frac{\frac{1}{n} \sum_{i=1}^n [E_L(i) + E_Q(i)]^2}{E_{\text{rms}}}} \cdot 100\%$$

where  $E_{\text{rms}}$  is the rms signal voltage level.

This expression indicates that, in general, there is a correlation between the THD and the square root of the sum of the squares of the linearity errors at each digital word of interest. However, this expression does not mean that the worst-case linearity error of the D/A is directly correlated to the THD.

For PCM54/55 the test period was chosen to be 22.7 $\mu$ s (44.1kHz) which is compatible with the EIAJ STC-007 specification for PCM audio. The test frequency is 420Hz and the amplitude of the input signal is 0dB, -20dB, and -60dB down from full scale.

Figure 4 shows the typical THD as a function of output voltage.

Figure 5 shows typical THD as a function of frequency.

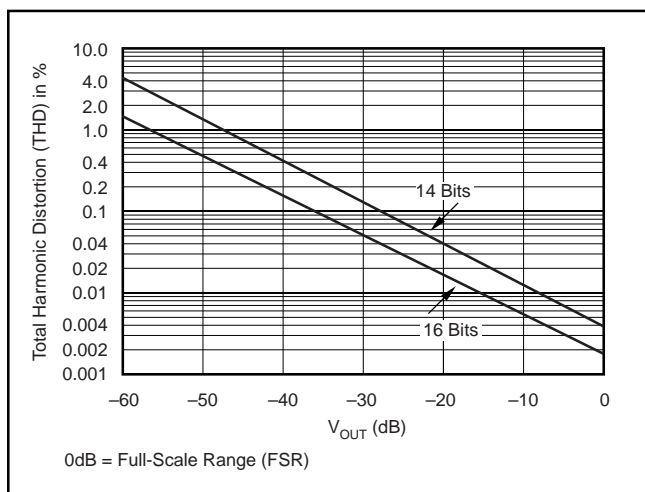

FIGURE 4. Total Harmonic Distortion (THD) vs  $V_{\text{OUT}}$ .

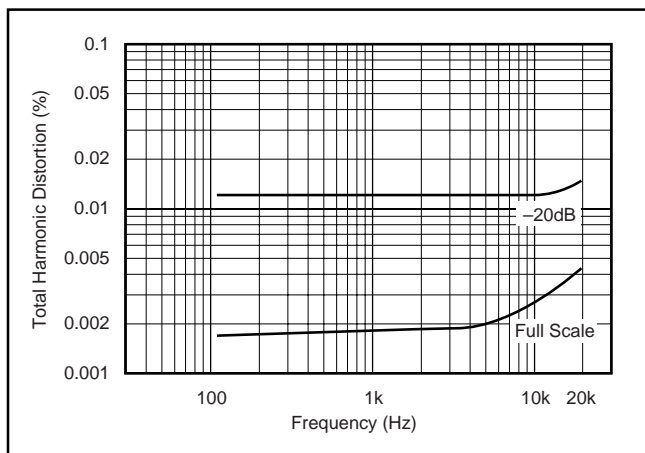

FIGURE 5. Total Harmonic Distortion (THD) vs Frequency.

## INSTALLATION AND OPERATING INSTRUCTIONS

### POWER SUPPLY CONNECTIONS

For optimum performance and noise rejection, power supply decoupling capacitors should be added as shown in the connections diagram. These capacitors (1 $\mu$ F tantalum or electrolytic recommended) should be located close to the converter.

### MSB ERROR ADJUSTMENT PROCEDURE (OPTIONAL)

The MSB error of the PCM54 and PCM55 can be adjusted to make the differential linearity error (DLE) at BPZ essentially zero. This is important when the signal output levels are very low because zero crossing noise (DLE at BPZ) becomes very significant when compared to the small code changes occurring in the LSB portion of the converter.

Differential linearity error at bipolar zero is guaranteed to meet data sheet specifications without any external adjustment. However, a provision has been made for an optional adjustment of the MSB linearity point which makes it possible to eliminate DLE error at BPZ (PCM54 only). Two procedures are given to allow either static or dynamic adjustment. The dynamic procedure is preferred because of the difficulty associated with the static method (accurately measuring 16-bit LSB steps).

To statically adjust DLE at BPZ, refer to the circuit shown in Figure 6 or the PCM54 connection diagram. After allowing ample warm-up time (20-30 minutes) to assure stable operation of the PCM54, select input code 8000 hexadecimal (all bits off except the MSB). Measure and record it. Change the digital input code to 7FFF hexadecimal (all bits off except the MSB). Adjust the 100k $\Omega$  potentiometer to make the audio output read 92 $\mu$ V more than the voltage reading of the previous code (a 1LSB step = 92 $\mu$ V).

A much simpler method is to dynamically adjust the DLE at BPZ. Again, refer to Figure 6 or the PCM54 connection diagram for circuitry and component values. Assuming the device has been installed in a digital audio application circuit, send the appropriate digital input to produce a -60dB level sinusoidal output. While measuring the THD of the audio circuit output, adjust the 100k $\Omega$  potentiometer until a minimum level of distortion is observed.

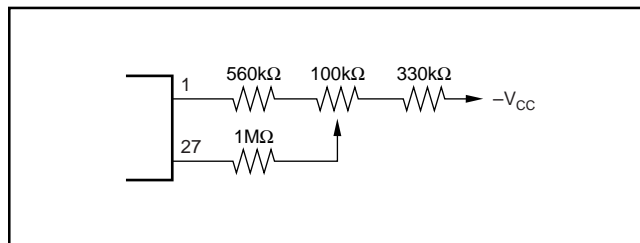

FIGURE 6. MSB Differential Linearity at Bipolar Zero Adjustment Circuit (optional).

# INSTALLATION CONSIDERATIONS

If the optional external MSB error circuitry is used (PCM54), a potentiometer with adequate resolution and a TCR of 100ppm/°C or less is required. Also, extra care must be taken to insure that no leakage path (either AC or DC) exists to pin 27 (PCM54). If circuit is not used, pin 1 (PCM54) should be terminated to common with a 0.01μF capacitor.

The PCM converter and the wiring to its connectors should be located to provide the optimum isolation from sources of RFI and EMI. The important consideration in the elimination of RF radiation or pickup is loop area; therefore, signal leads and their return conductors should be kept close together. This reduces the external magnetic field along with any radiation. Also, if a signal lead and its return conductor are wired close together, they represent a small flux-capture cross section for any external field. This reduces radiation pickup in the circuit.

# APPLICATIONS

A sample/hold amplifier, or “deglitcher”, is required at the output of the D/A converter for both the left and right channel, as shown in Figure 7. The S/H amplifier for the left channel is composed of  $A_2$ ,  $SW_1$ , and associated circuitry.  $A_2$  is used as an integrator to hold the analog voltage in  $C_1$ . Since the source and drain of the FET switch operates at a virtual ground when “C” and “B” are closed in the simple mode, there is no increase in distortion caused by the modulation effect of  $R_{ON}$  by the audio signal.

Figure 8 shows the deglitcher control signals for both the left and right channels which are produced by the timing control logic. A delay of 2.5μs ( $t_w$ ) is provided to eliminate the glitch and allow the output of the PCM54-V to settle within a small error band around its final value before connecting it to the channel output.

Due to the fast settling time of the PCM54-V, it is possible to minimize the delay between the left channel and right channel outputs when using a single D/A converter for both channels. This is important because the left and right channel data is recorded in phase and use of a slower D/A converter would result in significant phase error at the higher audio frequencies.

A low-pass filter is required at the S/H output to remove all unwanted frequency components caused by the sampling frequency as well as the discrete nature of the D/A converter output. The filter must have a flat amplitude response over the entire audio band (0 to 20kHz) and a very high attenuation above 20kHz. Most previous digital audio circuits used a high-order (9-13 pole) analog filter. However, the phase response of an analog filter with these amplitude characteristics is nonlinear and can disturb the pulse-shaped characteristics of the transients contained in music.

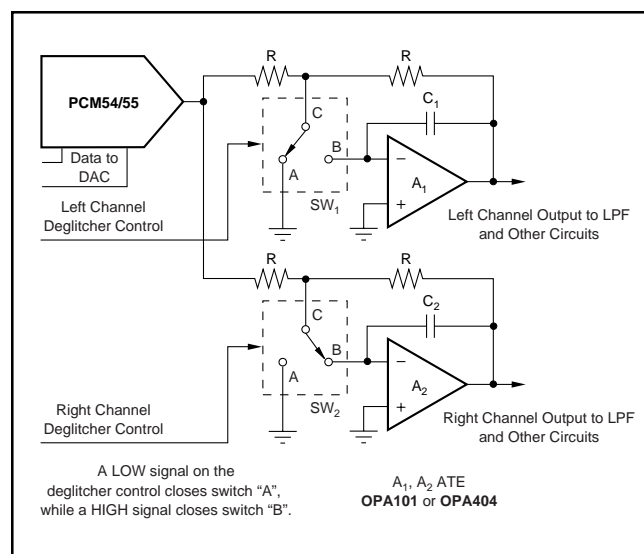

FIGURE 7. A Sample/Hold Amplifier (deglitcher) is Required at the Digital-to-Analog Output for Both Left and Right Channels.

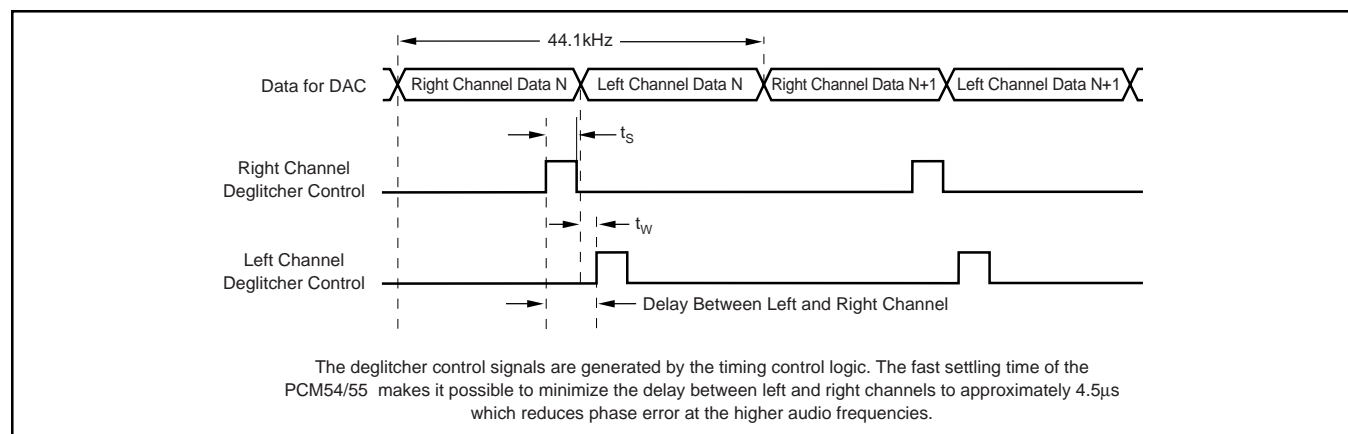

FIGURE 8. Timing Diagram for the Deglitcher Control Signals.

**PACKAGING INFORMATION**

Orderable Device	Status <sup>(1)</sup>	Package Type	Package Drawing	Pins	Package Qty	Eco Plan <sup>(2)</sup>	Lead/Ball Finish	MSL Peak Temp <sup>(3)</sup>
PCM54HP	ACTIVE	PDIP	NTD	28	12	TBD	Call TI	N / A for Pkg Type
PCM55HP	ACTIVE	SOP	DVK	24	30	Green (RoHS & no Sb/Br)	42 NI-FE SNBI	Level-2-260C-1 YEAR
PCM55HP-1	OBSOLETE	SOP	DVK	24		TBD	Call TI	Call TI
PCM55HP-1G6	OBSOLETE	SOP	DVK	24		TBD	Call TI	Call TI
PCM55HP/1K	ACTIVE	SOP	DVK	24	1000	Green (RoHS & no Sb/Br)	42 NI-FE SNBI	Level-2-260C-1 YEAR
PCM55HP/1KG6	ACTIVE	SOP	DVK	24	1000	Green (RoHS & no Sb/Br)	42 NI-FE SNBI	Level-2-260C-1 YEAR
PCM55HPG6	ACTIVE	SOP	DVK	24	30	Green (RoHS & no Sb/Br)	42 NI-FE SNBI	Level-2-260C-1 YEAR
PCM55JP	ACTIVE	SOP	DVK	24		TBD	Call TI	Call TI

<sup>(1)</sup> The marketing status values are defined as follows:

**ACTIVE:** Product device recommended for new designs.

**LIFEBUY:** TI has announced that the device will be discontinued, and a lifetime-buy period is in effect.

**NRND:** Not recommended for new designs. Device is in production to support existing customers, but TI does not recommend using this part in a new design.

**PREVIEW:** Device has been announced but is not in production. Samples may or may not be available.

**OBSOLETE:** TI has discontinued the production of the device.

<sup>(2)</sup> Eco Plan - The planned eco-friendly classification: Pb-Free (RoHS), Pb-Free (RoHS Exempt), or Green (RoHS & no Sb/Br) - please check <http://www.ti.com/productcontent> for the latest availability information and additional product content details.

**TBD:** The Pb-Free/Green conversion plan has not been defined.

**Pb-Free (RoHS):** TI's terms "Lead-Free" or "Pb-Free" mean semiconductor products that are compatible with the current RoHS requirements for all 6 substances, including the requirement that lead not exceed 0.1% by weight in homogeneous materials. Where designed to be soldered at high temperatures, TI Pb-Free products are suitable for use in specified lead-free processes.

**Pb-Free (RoHS Exempt):** This component has a RoHS exemption for either 1) lead-based flip-chip solder bumps used between the die and package, or 2) lead-based die adhesive used between the die and leadframe. The component is otherwise considered Pb-Free (RoHS compatible) as defined above.

**Green (RoHS & no Sb/Br):** TI defines "Green" to mean Pb-Free (RoHS compatible), and free of Bromine (Br) and Antimony (Sb) based flame retardants (Br or Sb do not exceed 0.1% by weight in homogeneous material)

<sup>(3)</sup> MSL, Peak Temp. -- The Moisture Sensitivity Level rating according to the JEDEC industry standard classifications, and peak solder temperature.

**Important Information and Disclaimer:**The information provided on this page represents TI's knowledge and belief as of the date that it is provided. TI bases its knowledge and belief on information provided by third parties, and makes no representation or warranty as to the accuracy of such information. Efforts are underway to better integrate information from third parties. TI has taken and continues to take reasonable steps to provide representative and accurate information but may not have conducted destructive testing or chemical analysis on incoming materials and chemicals. TI and TI suppliers consider certain information to be proprietary, and thus CAS numbers and other limited information may not be available for release.

In no event shall TI's liability arising out of such information exceed the total purchase price of the TI part(s) at issue in this document sold by TI to Customer on an annual basis.



**TAPE AND REEL INFORMATION**



**QUADRANT ASSIGNMENTS FOR PIN 1 ORIENTATION IN TAPE**



\*All dimensions are nominal

Device	Package Type	Package Drawing	Pins	SPQ	Reel Diameter (mm)	Reel Width W1 (mm)	A0 (mm)	B0 (mm)	K0 (mm)	P1 (mm)	W (mm)	Pin1 Quadrant
PCM55HP/1K	SOP	DVK	24	1000	330.0	25.4	12.6	17.5	2.95	16.0	24.0	Q1

**TAPE AND REEL BOX DIMENSIONS**



\*All dimensions are nominal

Device	Package Type	Package Drawing	Pins	SPQ	Length (mm)	Width (mm)	Height (mm)
PCM55HP/1K	SOP	DVK	24	1000	346.0	346.0	41.0

## IMPORTANT NOTICE

Texas Instruments Incorporated and its subsidiaries (TI) reserve the right to make corrections, modifications, enhancements, improvements, and other changes to its products and services at any time and to discontinue any product or service without notice. Customers should obtain the latest relevant information before placing orders and should verify that such information is current and complete. All products are sold subject to TI's terms and conditions of sale supplied at the time of order acknowledgment.

TI warrants performance of its hardware products to the specifications applicable at the time of sale in accordance with TI's standard warranty. Testing and other quality control techniques are used to the extent TI deems necessary to support this warranty. Except where mandated by government requirements, testing of all parameters of each product is not necessarily performed.

TI assumes no liability for applications assistance or customer product design. Customers are responsible for their products and applications using TI components. To minimize the risks associated with customer products and applications, customers should provide adequate design and operating safeguards.

TI does not warrant or represent that any license, either express or implied, is granted under any TI patent right, copyright, mask work right, or other TI intellectual property right relating to any combination, machine, or process in which TI products or services are used. Information published by TI regarding third-party products or services does not constitute a license from TI to use such products or services or a warranty or endorsement thereof. Use of such information may require a license from a third party under the patents or other intellectual property of the third party, or a license from TI under the patents or other intellectual property of TI.

Reproduction of TI information in TI data books or data sheets is permissible only if reproduction is without alteration and is accompanied by all associated warranties, conditions, limitations, and notices. Reproduction of this information with alteration is an unfair and deceptive business practice. TI is not responsible or liable for such altered documentation. Information of third parties may be subject to additional restrictions.

Resale of TI products or services with statements different from or beyond the parameters stated by TI for that product or service voids all express and any implied warranties for the associated TI product or service and is an unfair and deceptive business practice. TI is not responsible or liable for any such statements.

TI products are not authorized for use in safety-critical applications (such as life support) where a failure of the TI product would reasonably be expected to cause severe personal injury or death, unless officers of the parties have executed an agreement specifically governing such use. Buyers represent that they have all necessary expertise in the safety and regulatory ramifications of their applications, and acknowledge and agree that they are solely responsible for all legal, regulatory and safety-related requirements concerning their products and any use of TI products in such safety-critical applications, notwithstanding any applications-related information or support that may be provided by TI. Further, Buyers must fully indemnify TI and its representatives against any damages arising out of the use of TI products in such safety-critical applications.

TI products are neither designed nor intended for use in military/aerospace applications or environments unless the TI products are specifically designated by TI as military-grade or "enhanced plastic." Only products designated by TI as military-grade meet military specifications. Buyers acknowledge and agree that any such use of TI products which TI has not designated as military-grade is solely at the Buyer's risk, and that they are solely responsible for compliance with all legal and regulatory requirements in connection with such use.

TI products are neither designed nor intended for use in automotive applications or environments unless the specific TI products are designated by TI as compliant with ISO/TS 16949 requirements. Buyers acknowledge and agree that, if they use any non-designated products in automotive applications, TI will not be responsible for any failure to meet such requirements.

Following are URLs where you can obtain information on other Texas Instruments products and application solutions:

### Products

Amplifiers	<a href="http://amplifier.ti.com">amplifier.ti.com</a>
Data Converters	<a href="http://dataconverter.ti.com">dataconverter.ti.com</a>
DSP	<a href="http://dsp.ti.com">dsp.ti.com</a>
Clocks and Timers	<a href="http://www.ti.com/clocks">www.ti.com/clocks</a>
Interface	<a href="http://interface.ti.com">interface.ti.com</a>
Logic	<a href="http://logic.ti.com">logic.ti.com</a>
Power Mgmt	<a href="http://power.ti.com">power.ti.com</a>
Microcontrollers	<a href="http://microcontroller.ti.com">microcontroller.ti.com</a>
RFID	<a href="http://www.ti-rfid.com">www.ti-rfid.com</a>
RF/IF and ZigBee® Solutions	<a href="http://www.ti.com/lprf">www.ti.com/lprf</a>

### Applications

Audio	<a href="http://www.ti.com/audio">www.ti.com/audio</a>
Automotive	<a href="http://www.ti.com/automotive">www.ti.com/automotive</a>
Broadband	<a href="http://www.ti.com/broadband">www.ti.com/broadband</a>
Digital Control	<a href="http://www.ti.com/digitalcontrol">www.ti.com/digitalcontrol</a>
Medical	<a href="http://www.ti.com/medical">www.ti.com/medical</a>
Military	<a href="http://www.ti.com/military">www.ti.com/military</a>
Optical Networking	<a href="http://www.ti.com/opticalnetwork">www.ti.com/opticalnetwork</a>
Security	<a href="http://www.ti.com/security">www.ti.com/security</a>
Telephony	<a href="http://www.ti.com/telephony">www.ti.com/telephony</a>
Video & Imaging	<a href="http://www.ti.com/video">www.ti.com/video</a>
Wireless	<a href="http://www.ti.com/wireless">www.ti.com/wireless</a>

Mailing Address: Texas Instruments, Post Office Box 655303, Dallas, Texas 75265  
Copyright © 2008, Texas Instruments Incorporated